

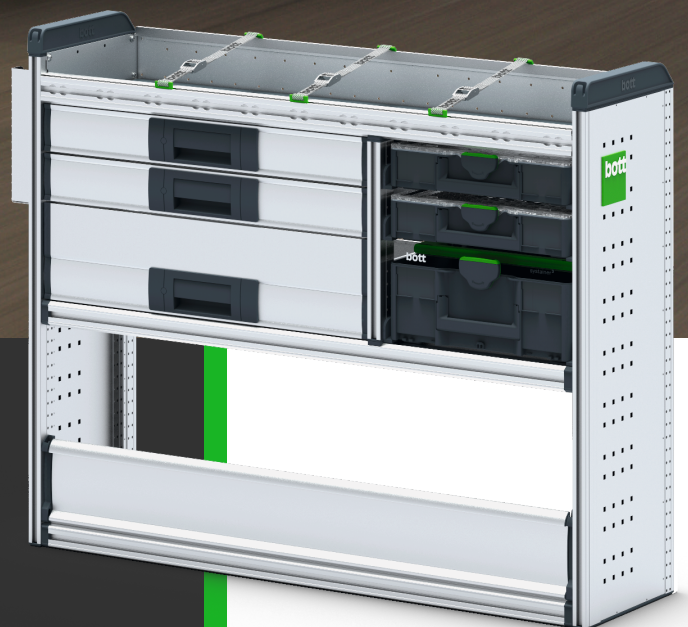

The TGE industry solution

bott



The maintenance and service trolley



## MAN TGE | Equipped ex-factory

No-one likes waiting for their new vehicle, particularly when it's a MAN TGE.

Which is why there is a whole selection of branch-specific equipping solutions and custom equipment available for installation directly in the factory. You can configure your MAN TGE exactly to your requirements with integrated shelf systems – so easily and quickly that you can almost see the dust rising. If you would rather have a MAN TGE with equipment solution within only a few days, we offer you numerous complete vehicles that are ready for immediate delivery with our vans



### 639YF (PR-Nr. YYH) Basic package

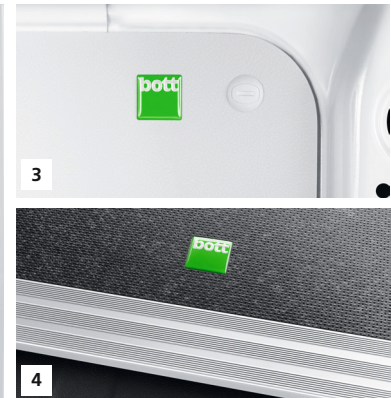
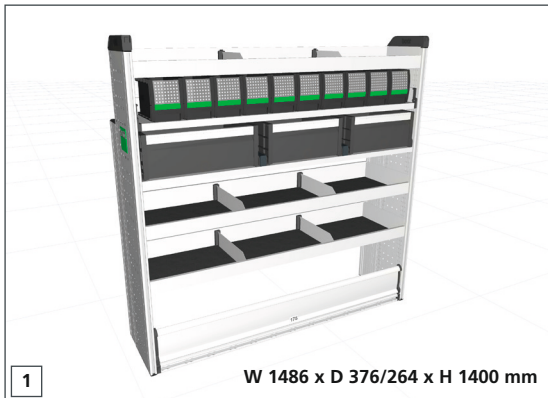

- 1** Module comprising:  
1 floor storage compartment with integrated load restraint and aluminium drop front,  
3 aluminium shelves with dividers and anti-slip mats,  
case support beams with 3 varioSlide, 1 bottBox shelf with bottBoxes  
Weight 109 kg

- 2** Lashing rail on the left and right, halfway up, for the later installation of further options or individual modules  
**3** Custom-fit side lining made of recyclable polypropylene, 4 mm thick with structured surface on one side, UV-resistant, low weight, non-corroding and non-rotting, resistant to chemicals, extremely light and good to clean  
**4** bott vario floor made of 12 mm birch plywood with sturdy and slip-resistant synthetic resin film coating, incl. edge protection.

### 63BAU (PR-Nr. YK2) Option 1a



- 5** Module comprising:  
1 floor storage compartment with integrated load restraint and aluminium drop front, 1 bearer with integrated load restraint, 1 drop-front shelf with aluminium drop front and anti-slip mat,  
2 Systainer<sup>3</sup>, 2 drawers with anti-slip mat,  
1 aluminium shelf with dividers and anti-slip mat,  
1 bottBox shelf with bottBoxes, 1 lashing strap  
Weight 34 kg

**Only in conjunction with the basic package**

### 63BAW (PR-NR. YXO) Option 1b

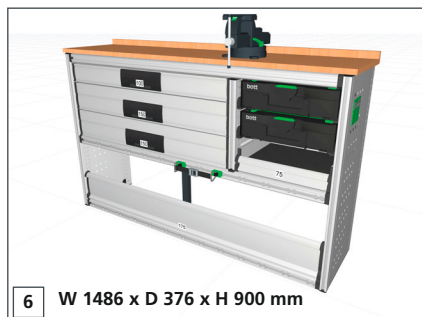

- 6** Module comprising:  
1 floor storage compartment with integrated load restraint and aluminium drop front, 1 bearer with integrated load restraint, 3 drawers with anti-slip mat, 1 drop-front shelf with aluminium drop front and anti-slip mat, 2 Systainer<sup>3</sup>, 1 multiplex worktop, vice 125mm, 1 lashing strap  
Weight 59 kg

**Only in conjunction with the basic package**

### 63BAX (PR-Nr. YK4) Option 2

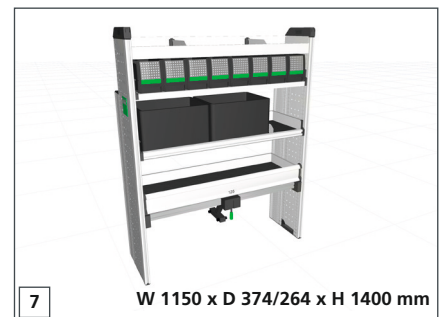

- 7** Module comprising:  
1 floor storage compartment with case clamping unit, 1 drop-front shelf with aluminium drop front and anti-slip mat,  
1 box shelf with euroboxes, 1 bottBox shelf with bottBoxes, 1 aluminium shelf with dividers and anti-slip mat  
Weight 26 kg

**Only in conjunction with the basic package**

## bott vario | Combination elements and accessory packages

The modular design opens up extremely flexible, tailor-made installation options for your L3/H3 and H2. The basic equipment alone will create a solid basis for organised, efficient working processes on mobile service missions.

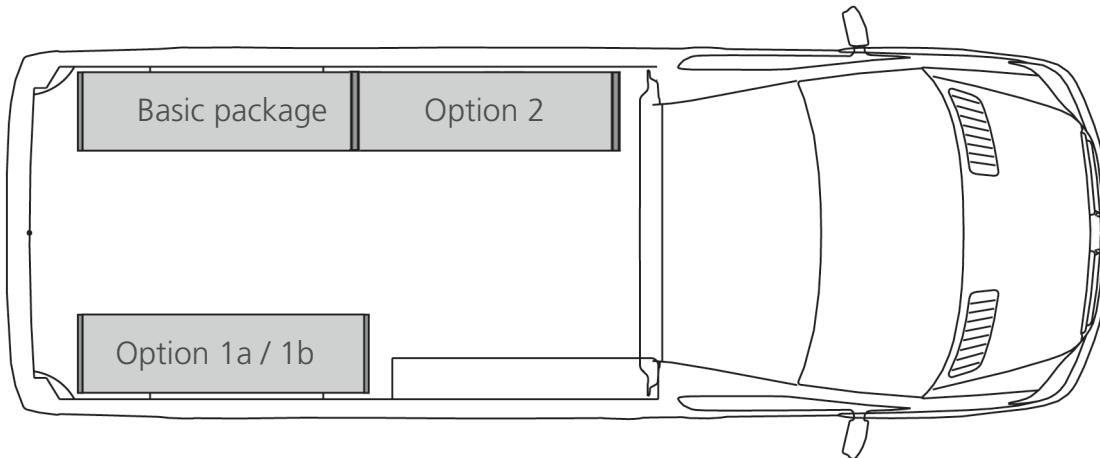

### 63BAZ (PR-Nr. YX1) Option 3



- 1** Set comprising:  
 Folding worktop incl. vice - for working outside the vehicle  
 Zinc-plated sheet steel, beech multiplex worktop  
 Jaw width 125 mm, weight 24 kg  
**Only in conjunction with option 1a or 1b**

### 63BA0 (PR-Nr. YK6)



- 2** Set comprising:  
 Venting elements for the roof and vehicle floor  
 2 lashing rails with protective strip with one ratchet strap each, load capacity up to 500 daN  
**Only in conjunction with the basic package**

### 63BA4 (PR-Nr. YX3) Load restraint

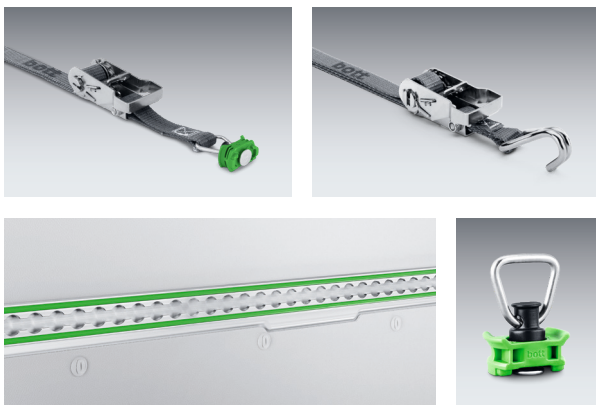

- Set consisting of:  
 Lashing rail with protective strip on the bulkhead incl. lashing straps with fitting and ratchet, lashing strap with hook and ratchet for fittings and lashing eyes, fittings for rails and shelves for attachment of the straps with hook (floor lashing options are already included in the basic shelf, shelf 1a and shelf 1b)  
**Only in conjunction with the basic package**



[www.bott-group.com](http://www.bott-group.com)

Bott GmbH & Co. KG, Bahnstraße 17, 74405 Gaildorf, Germany

Dialog-aktiv*aktiv* telesales team: Phone: +49 (0)79 71 / 251-251, Fax: +49 (0)79 71 / 251-205

